

MAPX	MODIFICATION	DATE

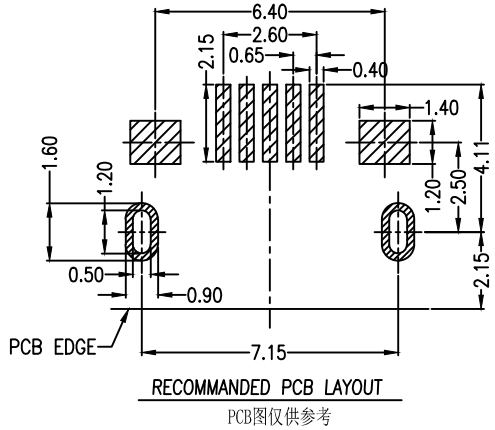
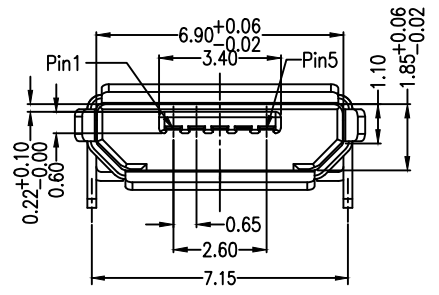
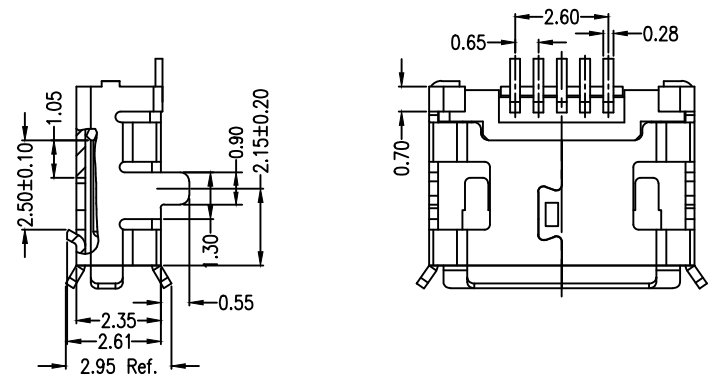
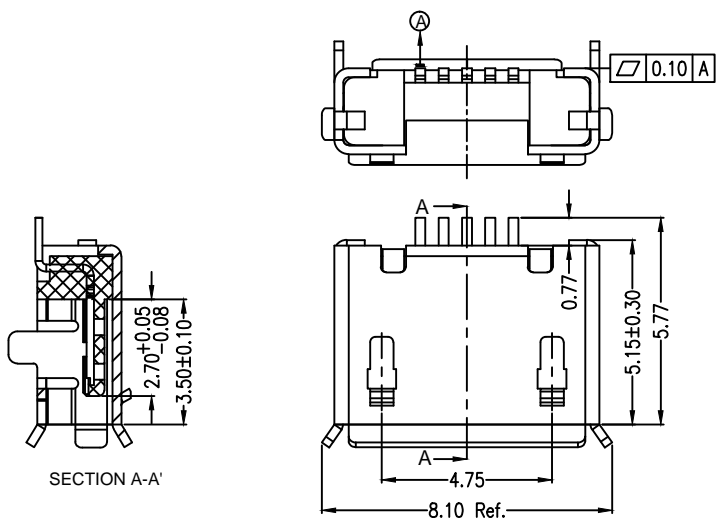

- Note:
- Material:
 - Housing: High temperature thermoplastic with g.f,UL94v-0
 - Contact: copper alloy,t=0.20mm
 - Shell: copper alloy,t=0.25mm
 - Specification:
 - Current rating:1.5PIN 1.8A Max/2,3,4PIN 1A Max.
 - Dielectric withstanding voltage: 100 V(ac) for 1 min.
 - Contact resistance: 30 mΩ Max.
 - Insulation resistance: 100 MΩ Min.
 - Total mating force: 3.57 Kgf Max.
 - Total unmating force: 1.0 Kgf Min.
 - Temperature range: -30°C~80°C

产品图 PRODUCT CHART DWG		深圳市精拓金电子有限公司					
公差一览表 TOLERANCE UNLESS OTHERWISE		单位 UNITS	MM	制图 DRAWING	YANG	制图料号 PRODUCT PART NO.	920-A52A2021S10107
X.	±0.30 X.	±5.°				产品名称 PRODUCT NO.	MICRO/5P-F 两脚DIP7.2有边无柱 加焊脚端子长端0.75SMT
.X	±0.25 .X	±2.°	比例 SCALE	1:1	审核 CHKD	郭志富	
.XX	±0.20 .XX	±1.°	日期 DATE	2019.11.23	核准 APPD	黄国荣	角法 VIEW
.XXX	±0.10 .XXX	±0.5°					版本 VER
							AO